

TOOL BENCH - MINI TOOL HOLDER

installation, use and maintenance instructions



* **BEFORE USING THE TOOL BENCH OR THE TOOL HOLDER** make sure that the floors are in good condition and that they have an appropriate consistency for the capacity of the cabinet. In the case of floors with slight unevenness, shim the cabinet and check the proper operation of the lock.

* **DURING TRANSIT WITH PALLET TRUCKS** the drawers must be closed and the front part must be facing the operator.

* **THE OPENING AND CLOSING OF DRAWERS** must be done with only one drawer at a time.

* **MAKE SURE THE KEY IS IN OPENING POSITION BEFORE CLOSING THE DRAWERS.**

MOUNTING THE TOOL BENCH

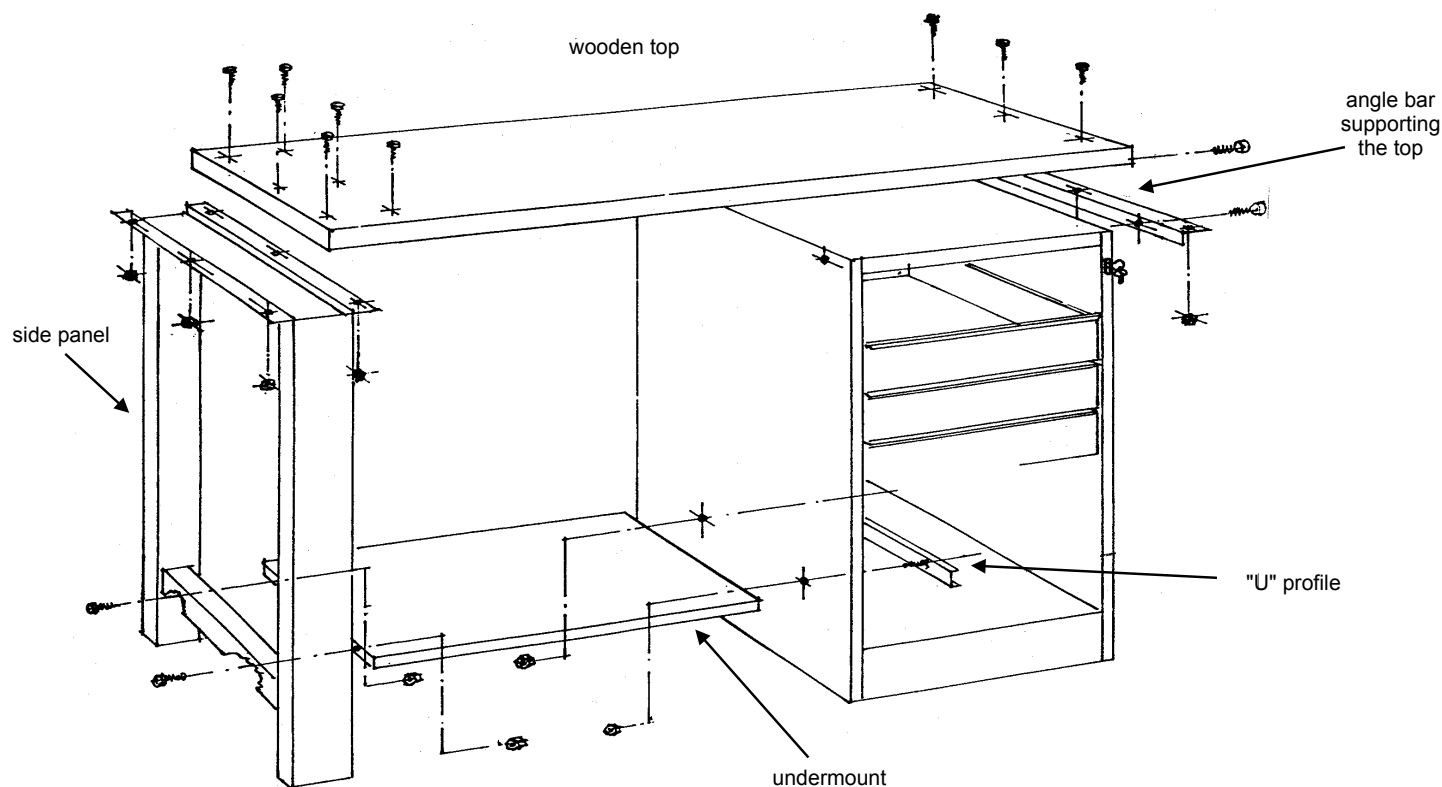

1 Attach the angle bar supporting the top in the upper holes of the outer side of the drawers unit with 2 flanged screws TE 8x16 near the welded nuts inside.

2 Pull out the drawers near the lower holes of the drawers unit.

3 Insert the "U" profile inside the drawers unit, and with 2 flanged screws TE 8x16, attach it to the drawers unit and undermount, then lock by means of the washer and of 2 nuts of 8; finish the installation of the undermount by securing the side panel using 2 flanged TE screws 8x16 and 2 tab nuts.

4 Place the work top on the structures and insert the countersunk head screws 8x55 in correspondence with the holes on the side and/or the support angle bar of the top; screw with washers and nuts supplied.

5 Once the assembly is completed, check and tighten all screws.

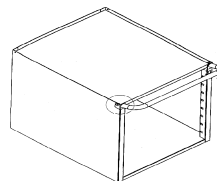

6 **FITTING THE TROLLEY HANDLE**

Within the 1st or 2nd drawer, the handle to be fixed is inserted with 2 oval head screws 6x12.

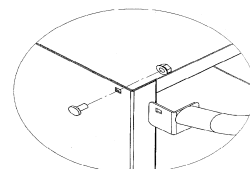

USE OF DRAWERS UNIT

7

EXTRACTION OF DRAWERS.

Check that all the drawers are perfectly closed, completely remove the drawer and, slightly raising the front part, surpass the 1st and the 2nd stop. To facilitate extraction, close the key to unlock the bearing after the 2nd stop and reopen after insertion.

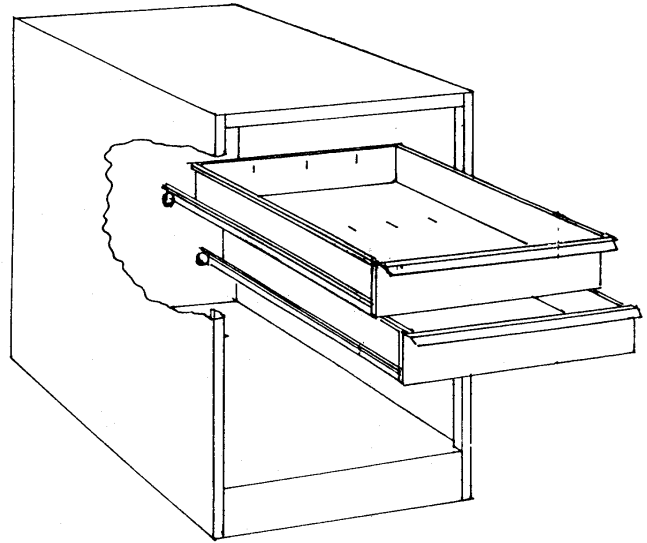

8

LOCKING THE SLOTTED SEPARATOR.

Insert the separator in the desired position and twist the tab through the bottom of the drawer.

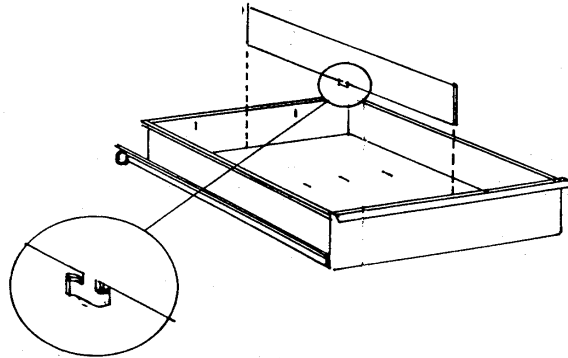

9

ANOMALIES IN THE OPENING/CLOSING OF DRAWERS WITH ANTI-TIPPING.

* Ensure that all drawers are correctly closed.

* Unlock the key and **open 1 drawer at a time, making sure that the others are closed.**

* If the drawers do not close properly, pull the first drawers of the top part (see step "7") and, by stretching out an arm or with the help of a screwdriver, push downwards on the rod with the pins positioned to the left, to the bottom of the drawers unit. Re-insert the drawers, which should operate normally.

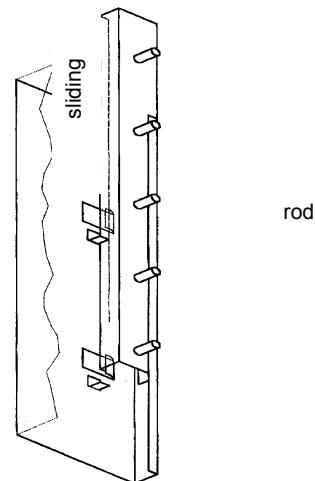

MAINTENANCE

Lubricate the bearings whenever it is deemed necessary in order to maintain a smooth sliding of the drawers. If any parts are damaged, have them replaced.